

Chapter 22. Shed Construction

22.1 BUILDING SHED FLOOR

22.2 BUILDING SHED WALLS

22.3 BUILDING SHED ROOF

22.4 ASSEMBLING SHED

22.5 FINISHING SHED

Tools needed by volunteers:

Hammer
Nail apron
Tape measure
Square
Utility knife
Pencil

Materials needed:

4x8 Treated plywood
4x8 OSB
2x4 Treated lumber
2x4 lumber
2x6 lumber
Roof trusses
Steel door
H-Clips
4" TimberLok® screws
1⁵/₈" Exterior screws (tan-colored)
2¹/₂" Exterior screws (tan-colored)
8d nails
16d nails
2³/₈" Collated nails
3¹/₄" Collated nails

Tools and equipment needed:

Generator
Extension cord
Chop saw
Circular saw
Table saw
Framing nailer
6' level
Framing square
C-clamp
5/16" Nut driver

Personal Protection Equipment:

Safety glasses (required)
Work gloves (recommended)

Reference Materials:

House Plan

Safety First! Review the Safety Checklist before performing tasks in this chapter.

22.1. BUILDING SHED FLOOR

22.1.1. Framing Floor

1. Cut two pieces of treated 2x4 to 96" lengths for end plates.
2. Cut five pieces of treated 2x4 to 93" lengths for floor joists.
3. Assemble the floor section as shown in Figure 22-1. Screw through the end plates into the end of each floor joist using two 2½" exterior screws in each joist.

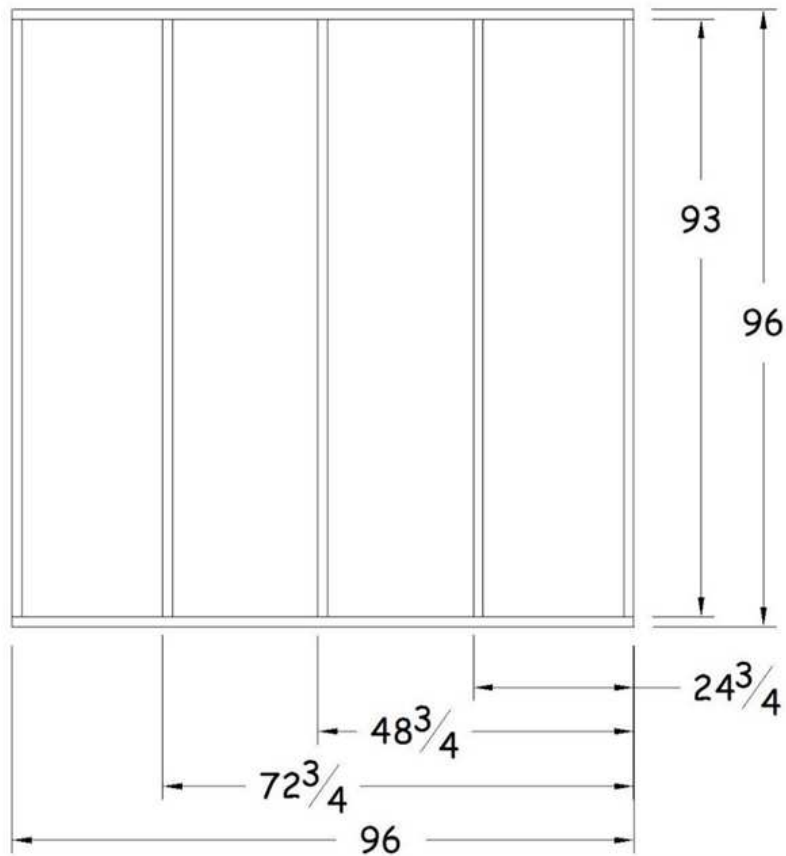

Figure 22-1. Floor Framing.

22.1.2. Sheathing Floor

1. Square each frame using diagonal measurements. Hold firmly in place until one sheet of treated plywood is secured in place.
2. Cover half of the floor with one 4'x8' sheet of $\frac{3}{4}$ " treated plywood, flush with the outside edge of one of the end plates (see Figure 22-2). Secure each corner with one $\frac{2}{3}$ " collated nail. Then attach the rest of the plywood to the end plate, joists and between joists with $\frac{1}{8}$ " exterior screws, spacing them 12" apart.
3. The second half of the floor will be sheathed with plywood on site during shed assembly.

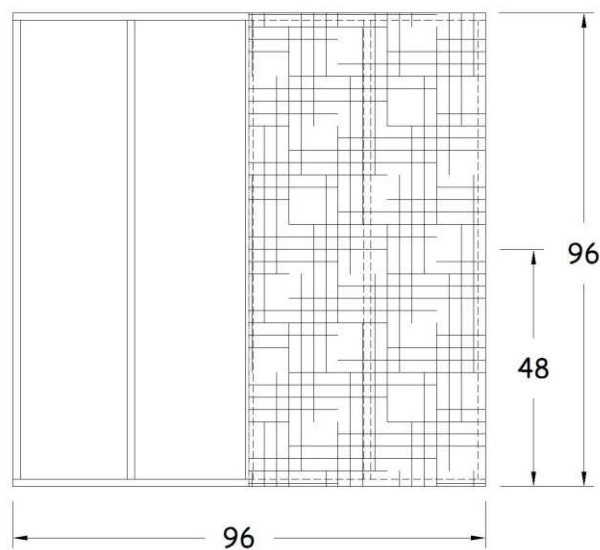

Figure 22-2. Floor Sheathing.

22.2. BUILDING SHED WALLS

22.2.1. Framing Walls

1. Front Wall:
 - a. Cut two pieces of 2x4 to 89" lengths. Pair them as upper and bottom plates and lay out stud locations as shown in Figure 22-3.

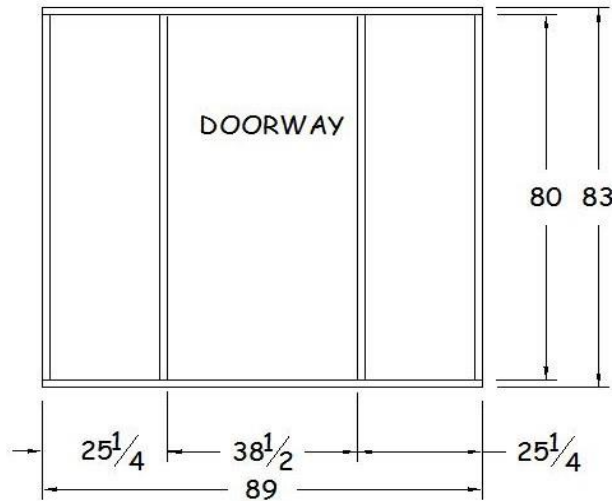

Figure 22-3. Front Wall Framing.

- b. Cut four 2x4s at 80" for studs.
- c. Assemble the wall by nailing through the upper and bottom plates into each stud with two 3 1/4" collated nails. Leave space for the doorway as shown in Figure 22-3.

2. Back Wall:

- a. Cut two pieces of 2x4 to 89" lengths. Pair them as upper and bottom plates and lay out stud locations on 24" centers as shown in Figure 22-4.
- b. Cut five 2x4s at 80" for studs.
- c. Assemble each wall by nailing through the upper and bottom plates into each stud with two 3/4" collated nails.

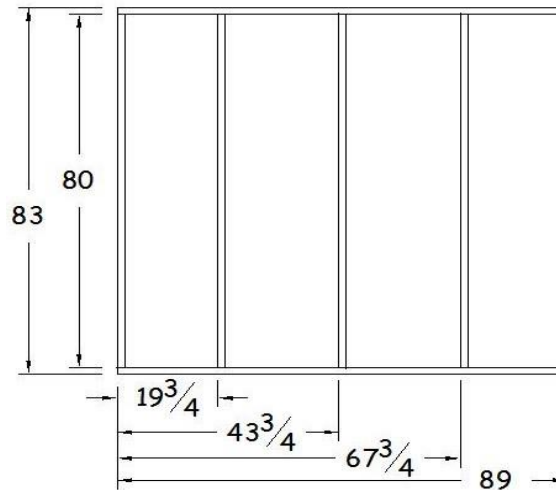

Figure 22-4. Back Wall Framing.

3. Side Walls:
 - a. Create two identical side walls.
 - b. Cut four pieces of 2x4 to 96" lengths. Pair them as upper and bottom plates (one pair for each wall) and lay out stud locations on 24" centers as in Figure 22-5.
 - c. Cut ten 2x4s at 80" for studs, five of them for each side wall.
 - d. Assemble each wall by nailing through the upper and bottom plates into each stud with two 3/4" collated nails.

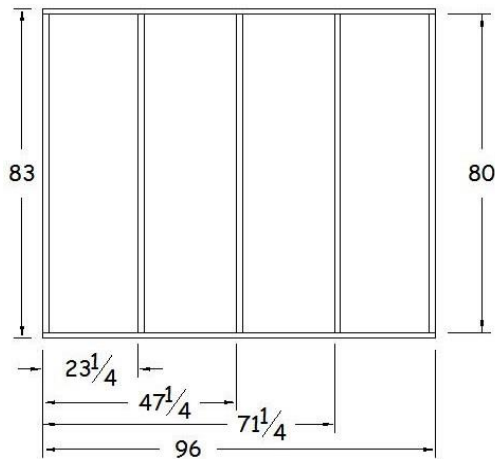

Figure 22-5. Side Wall Framing.

22.2.2. Sheathing Walls

1. Front Wall:

- a. Square the wall frame using diagonal measurements. Hold firmly in place until one sheet of OSB sheathing is secured in place.
- b. Cut two pieces of $\frac{1}{2}$ " OSB to $28\frac{3}{4}$ " x $84\frac{1}{2}$ ". Cut the 48" width of the sheets to $28\frac{3}{4}$ " first, then the length to $84\frac{1}{2}$ ". This leaves a $19\frac{1}{4}$ " wide OSB drop. Position the OSB rough side up, flush with the edge of the door opening, and flush with the top edge of the upper plate. There should be an overhang of $3\frac{1}{2}$ " on each side and an overhang on the bottom plate of $1\frac{1}{2}$ ". A scrap piece of 2x4 can be used as a gauge for the $3\frac{1}{2}$ " and $1\frac{1}{2}$ " overlaps. Nail each piece of OSB into studs and both plates every 8-12" using $\frac{23}{8}$ " collated nails. See Figure 22-6.

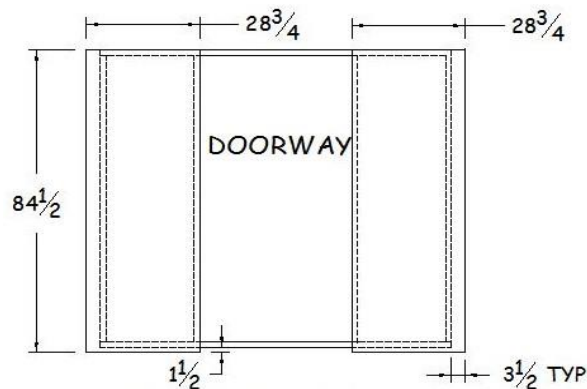

Figure 22-6. Front Wall Sheathing.

2. Back Wall:

- a. Square the wall frame using diagonal measurements. Hold firmly in place until one sheet of OSB sheathing is secured in place.
- b. Cover the upper half of the wall with a 48"x 96" sheet of 1/2" OSB with the rough side up, flush with the top edge of the upper plate, and overhanging each side by 3 1/2". Nail into all studs and the upper plate with 2 3/8" collated nails every 8-12".
- c. Cut an additional piece of 1/2" OSB, approximately 36 1/2" x 96", to fit below the upper section of OSB. This piece should fit tight to the upper OSB piece, overhang each side by 3 1/2", and overhang the bottom plate by 1 1/2". A scrap piece of 2x4 can be used as a gauge for the 3 1/2" and 1 1/2" overlap. Nail into all studs and the bottom plate with 2 3/8" collated nails every 8-12". See Figure 22-7.

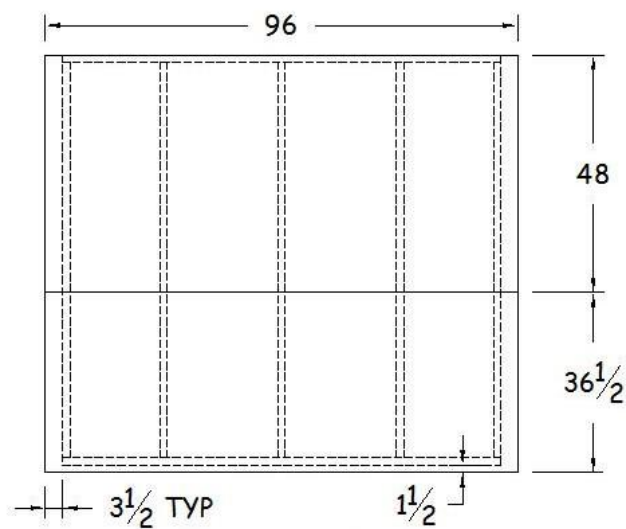

Figure 22-7. Back Wall Sheathing.

3. Side Walls:

- a. Square each of the two side wall frames using diagonal measurements. Hold firmly in place until one sheet of OSB sheathing is secured in place.
- b. Cover the upper half of each wall with a 48"x 96" sheet of 1/2" OSB with the rough side up. Nail into all studs and the upper plate with 2 3/8" collated nails every 8-12". These pieces should be flush with the top edge of the upper plate.
- c. Cut two additional pieces of 1/2" OSB approximately 36 1/2" x 96", to fit below the upper section of OSB. These pieces should fit tight to the upper OSB pieces and overhang the bottom plate by 1 1/2". Nail into all studs and the bottom plate with 2 3/8" collated nails every 8-12". See Figure 22-8.

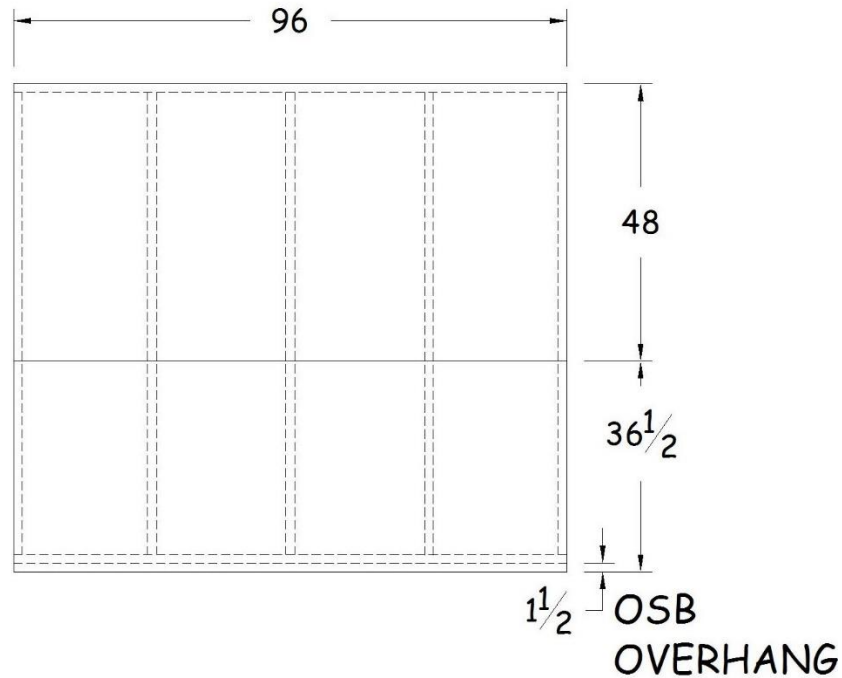

Figure 22-8. Side Wall Sheathing.

22.3. BUILDING SHED ROOF

22.3.1. Framing Roof

1. Create two identical roof sections.
2. Cut two sheathing pieces for the gable end of each roof section. Snap two diagonal lines from corner to corner on one 4'x8' sheet of ½" OSB to locate the center. Set a truss on the OSB with the truss peak at the center point and the bottom chord flush with the long edge of the 4'x8' sheet. Use a pencil to trace the top of the truss onto the OSB. Repeat this on the other half of the OSB sheet. Cut out these two large triangles and angle nail them with 2³/₈" collated nails to the two gable end trusses, rough side of the OSB out. (Angle nailing prevents nails from protruding through the other side.) Keep the lower edge flush with the bottom edge of the bottom chord. Trim the OSB flush along the top chord, if needed.
3. Cut two pieces of 2x4 exactly 4' long to create "truss ties". Set three trusses on their tails. Set one of the 4' truss ties on edge on top of the bottom truss chord and tight to the vertical truss support (see Figure 22-9). Position the truss tie flush to the outside edges of the two end trusses. Secure the truss tie to the two vertical truss supports on the end truss braces with two 3¹/₄" collated nails for each truss. Center the middle truss 24" from the outside edges of the end trusses and nail the truss tie to the vertical truss support with two 3¹/₄" collated nails.
4. Repeat Step 3 to create the second roof section.

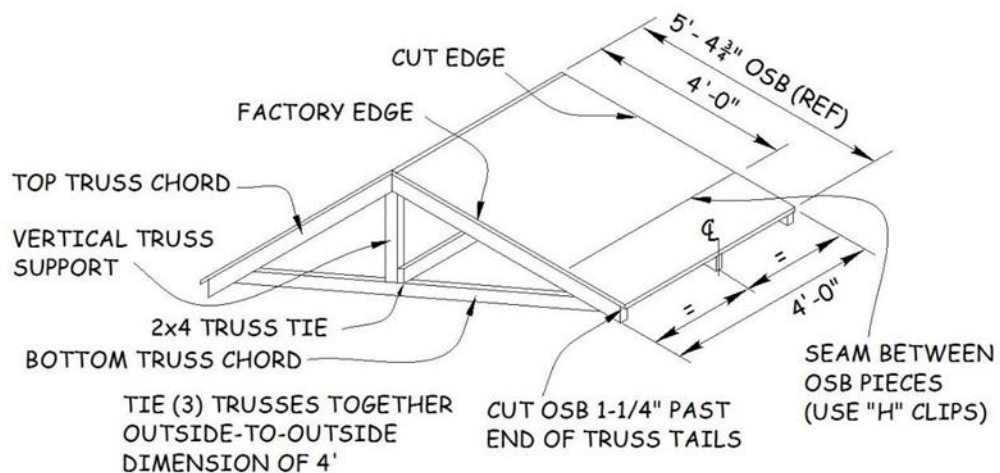

Figure 22-9. Shed Truss Component Assembly.

22.3.2. Sheathing Roof

1. Sheathe both sections of the roof.
2. Measure down 48” from the peak on the two end trusses and make a mark on those trusses. Snap a chalk line across all three trusses. Repeat on the other side of the peak.
3. Cut two 4’x8’ sheets of ½” OSB into four 4’x4’ pieces. Place one 4’x4’ piece of OSB on the trusses, rough side up, cut edge flush with the non-sheathed end truss and the bottom on the chalk line. Make sure end trusses are 48” from outside to outside as the OSB may not be cut straight. Make sure the center truss is still centered. Secure the OSB at each corner and in the center truss with one 2³/₈” collated nail. Repeat on the opposite side. Finish nailing every 8-12” along each truss.

NOTE: Aligning the cut edge with the sheathed end truss chord (See Figure 22-9) ensures the proper orientation of the OSB for roof strength.

4. Measure from the bottom edge of the OSB to the top of the truss tail. Add 1¼” to provide the desired overhang. Cut one 4x8 sheet of ½” OSB to this width. Then cut this piece into two 48” lengths. Center the OSB pieces on the trusses, rough side up. Add two H-Clips to the top edge of the OSB, roughly centered between each truss. Finish nailing every 8-12” along each truss.
5. Repeat steps 2-4 to sheathe the second roof section.
6. This concludes the off-site construction assembly steps, unless temporary assembly is required for photos. If photos are desired:
 - a. Turn the floor section upside down and place the second piece of treated plywood decking in position on the joists with all surfaces flush.
 - b. Assemble the wall sections with one 2½” exterior screw into the platform at each end of the bottom plate. Put three 2½” exterior screws in each wall intersection. Make sure all screws are secure.
 - c. Using an appropriate number of people, lift the two roof sections and place them on the walls, bringing the two sections together. Center the sections and take photos.
 - d. Disassemble roof, wall, and floor sections.
7. Store all assembled components on a flat surface to avoid warping prior to on-site construction.

22.4. ASSEMBLING SHED

22.4.1. Assembling and Securing the Floor Frame

1. Locate the 9'x9' pad of stone. Verify that the location conforms to the House Plan. Check the pad of stone for level on each side and diagonally. Adjust as necessary using a long 2x4 until stone is graded flat and level.
2. Check with the homeowner for desired door location. The default orientation is the door facing the street.
3. Cover the open half of the floor frame with a 4'x8' sheet of $\frac{3}{4}$ " treated plywood. Secure each corner with one $\frac{2\frac{3}{8}}$ " collated nail. Then attach the rest of the plywood to joists and between joists with $1\frac{5}{8}$ " exterior screws, spacing them 12" apart.
4. Flip the floor over onto the stone base, orient it so the plywood seam is NOT in the doorway, and adjust until level.

22.4.2. Setting and Temporarily Securing the Walls

1. Verify that all the wall components have been sheathed (see Figures 22-6, 22-7 and 22-8). There should be two 8' long walls for the sides, a short back wall and a short front wall with the door opening. The OSB sheathing on all walls should extend $1\frac{1}{2}$ " below the bottom plate to attach to the sides of the floor frame. On the short walls, the OSB should also extend beyond the end studs by $3\frac{1}{2}$ " to overlap the long wall end studs.
2. Set one long wall on either side of the floor frame, with the bottom plate ends flush to the outside of the floor frame, and with the OSB overhang tight to the side of the floor frame. Tack the $1\frac{1}{2}$ " overlap of the OSB to the floor frame at the ends and center with 8d nails to temporarily secure the bottom of the wall to the floor frame. Nail the bottom plate to the floor frame at both ends and in the center with $3\frac{1}{4}$ " collated nails. Nail about 1" away from the sheathing to make sure nails hit the floor frame.
3. Temporarily brace this first wall with a 2x4 x 10' from the front upper plate to the front floor frame (or have two people hold it in place). Set the short back wall in place with the $3\frac{1}{2}$ " OSB sheathing overlapping the first wall. Make sure the end back wall stud is tight to the long wall and the OSB is tight to the framing. Tack the $1\frac{1}{2}$ " overlap of the OSB to the floor frame at the ends and center with 8d nails. Nail the 2x4 corner together at the top and bottom with two $3\frac{1}{4}$ " collated nails. Nail the bottom plate to the floor frame at both ends and in the middle with $3\frac{1}{4}$ " collated nails. Nail about 1" away from the sheathing to make sure nails hit the floor frame.

4. Repeat Step 2 above with the remaining side wall and secure it to the back wall. Make sure the end wall stud is tight to the back wall and the OSB is tight to the framing. Tack the 1½” overlap of the OSB to the floor frame at the ends and center with 8d nails. Nail the 2x4 corner together at the top and bottom with two ¾” collated nails. Nail the bottom plate to the floor frame at both ends and in the middle with ¾” collated nails. Nail about 1” away from the sheathing to make sure nails hit the floor frame.
5. If used, remove the brace holding the first side wall and install the front doorway wall between the side walls. When the corners are tight and the OSB is tight to the framing, tack the 1½” overlap of the OSB to the floor frame at the ends and center with 8d nails. Nail the 2x4 corners together at the top and bottom with two ¾” collated nails. Nail the bottom plate to the floor frame at the two ends only with ¾” collated nails. Nail about 1” away from the sheathing to make sure nails hit the floor frame. **Do not** nail the bottom plate inside the doorway as that section will be removed when installing the door.

22.4.3. Completing the Wall Assembly

1. Verify that all corners are flush and tight, that all bottom plates are straight, and that the bottom of the sheathing is tight to the outside of the floor frame.
2. Check the corners for plumb, adjust if necessary (this may mean re-leveling the floor frame), and nail the overlapping OSB at the corners with angled 2⅜” collated nails every 6”.
3. Finish nailing the 1½” overlapping OSB at the bottom to the floor frame with 2⅜” collated nails every 8-12”. Finish nailing the bottom plates to the floor frame with ¾” collated nails, one in each bay between the studs. Finish nailing the corners with three additional ¾” collated nails in each corner stud.

22.4.4. Installing the Roof Sections

1. Place the two sections of the roof on top of the walls with gable ends over the front and back walls. Line up the two center trusses so that both the tails and roof sheathing are flush between the two sections. Clamp these two center trusses tightly together and angle nail with ¾” collated nails on both sides, about 12” apart with opposite sides staggered. Center the sections so the overhang is approximately the same on both eave sides and at each gable end
2. Starting with the gable end truss that is over the door, align the OSB on the gable end with the OSB on the front wall. Center the truss so the overhang is the same on both eave sides. Secure the gable end truss to the shed wall with two 16d nails toenailed through the OSB sheathing into each end of the upper plate. Then nail through the upper plate into the bottom chord of the truss with ¾” collated nails.
3. Once the front gable truss is secured, adjust the eave overhang at the back gable truss until centered. The overhang should be approximately the same at both ends

of the shed. If it is difficult to center the back truss, “rack” the assembly to one side until front and back are equal or the back end is centered. Secure the back gable end truss to the shed wall with two 16d nails toenailed through the OSB sheathing into each end of the upper plate. Then nail through the upper plate into the bottom chord of the truss with 3¼” collated nails.

4. Drive one 4” TimberLok® screw through the upper plate and into the bottom of the truss chord on both ends of the non-gable trusses.

22.5. FINISHING SHED

22.5.1. Installing Sub-Fascia

1. Measure from the peak of the OSB roof sheathing to the end of the truss tail at each gable end. Cut two pieces of 2x6x12’ to this length with the appropriate angle (about 5/12 pitch or 26.5°) on each end. Install the pieces with the top edge flush with the top of the OSB roof sheathing. Nail each 2x6 sub-fascia piece to the top truss chord with five pairs of 3¼” collated nails. Be sure to nail into the top chord itself, not just the OSB sheathing.
2. After each gable end sub-fascia has been installed, the bottom edge of the gable sub-fascia needs to be extended by ¾” to ensure proper fascia fit later. Cut ¾” OSB decking to a width of 1½” and a length measured from the bottom of each gable sub-fascia peak to the end of the gable sub-fascia. Nail to the bottom of the gable sub-fascia with 2⅜” collated nails every 12-16”.
3. On each eave side, measure the outside-to outside length from the front to the back gable sub-fascia installed in Step 1. Cut a 2x6 to this length for each side. Install with the crown up (if crowned), tight to the underside of the overhanging roof sheathing and flush to the outside of the gable sub-fascia. Nail with 3¼” collated nails, two into each truss tail and three into the gable end sub-fascia (at both ends of the eave sub fascia).

22.5.2. Installing Gable End Corners

1. Using a framing square, make a mark on each side wall at each corner corresponding to the height of the bottom edge of the eave sub-fascia. Measure down ½” from these marks and snap a chalk line from corner to corner at that point on both eave side walls. (These chalk lines will be used to reference the location of the bottom of the F-channel when siding the shed.)
2. At each corner of the shed, measure the distance from the inside of the eave end sub-fascia to the shed wall. Mark a scrap 2x6 to this length with one end of the length 5½” high and the other end 1¾” high (see Figure 22-10). Cut the angle on the 2x6 first (for safety reasons) then cut the 2x6 to the measured length for the gable end corner. Cut a scrap piece of 2x4 8-12” long for use as a gable end corner support block.

3. Lift the gable end corner up behind the gable sub-fascia and position between the wall OSB and the inside surface of the eave sub-fascia. Position the bottom flush with the mark made on the eave side wall and the bottom of the eave sub-fascia. Make sure it is flush with the wall OSB. Nail to the gable end sub-fascia (**on an angle** to prevent nailing through the sub-fascia) with one 3/4" collated nail and through the eave end sub-fascia with one 3/4" collated nail. Place the 2x4 gable end support block behind the gable end corner, flush the bottom surfaces, and nail with three 3/4" collated nails into the wall framing studs or upper plate. Then nail through the gable end corner into the support block with two 3/4" collated nails.
4. Repeat Steps 2 and 3 at each corner.

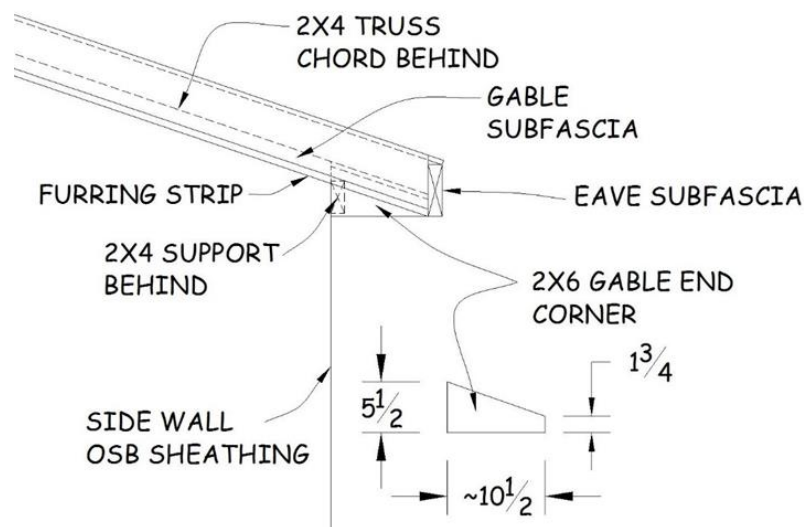

Figure 22-10. Gable End Corner Installation.

22.5.3. Completing the Shed

1. Install the shed door following instructions in Section 9.3.
2. Side the shed following instructions in Section 11.3.

Table 22-1. Storage Shed Materials Sheet.

Assembly Location	Quantity	Description
Off-Site	2	¾" x 4' x 8' treated plywood
	8	2 x 4 x 8' treated lumber (includes one extra)
	29	2 x 4 x 8' (includes one extra)
	6	5:12 x 8' roof truss with 12" overhang
	12	½" nominal 4' x 8' OSB
On-Site	2	2 x 6 x 10' for eave end sub-fascia
	2	2 x 6 x 12' for gable end sub-fascia
	1	2 x 4 x 10' for wall brace
	1	3'-0" outswing steel door